

General Instruction Sheet

Wall Mounted Display Cabinets - Flat pack

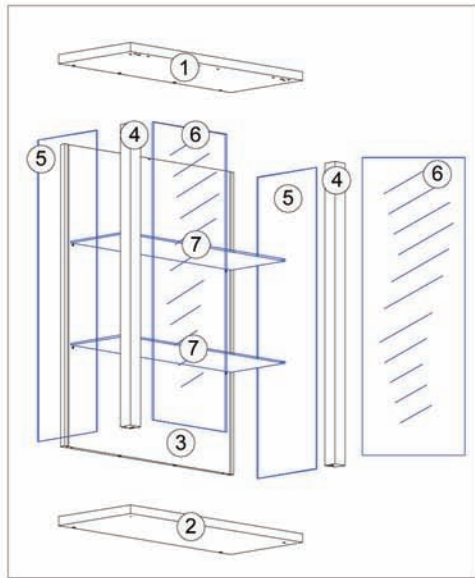

(A) 4x 8x30 	(B) 4x 6x30 	(C) 4x 5x60 	(D) 4x 6,3x50
(E) 4x 	(F) 4x 	(G) 2x 	(H) 2x
(I) 4x 	(J) 2x 	(K) 2x 	(L) 8x
(M) 1x Option 	(N) 2x 	(O) 4x 4x13 	(P) 2x 4x15
(Q) 2x 	(R) 2x 	(S) 8x 	

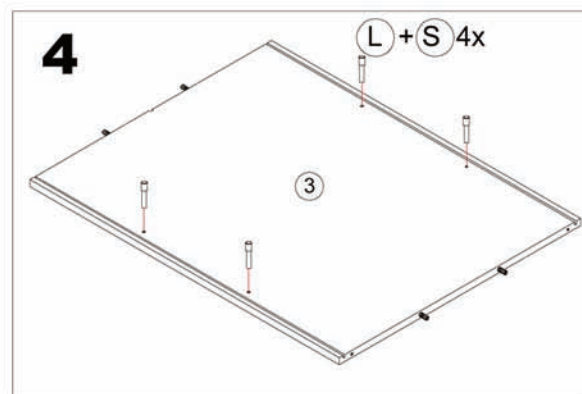
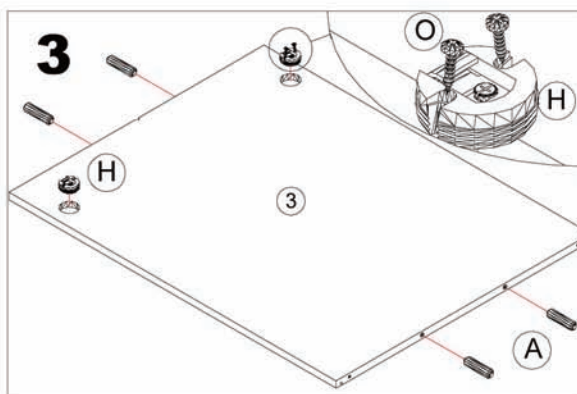
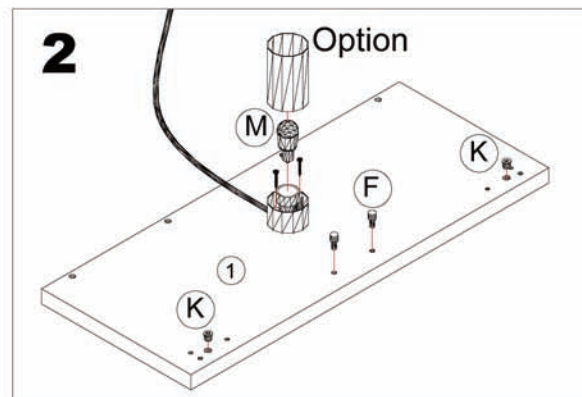
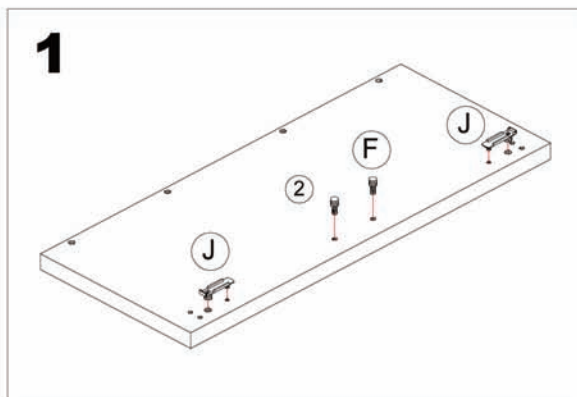

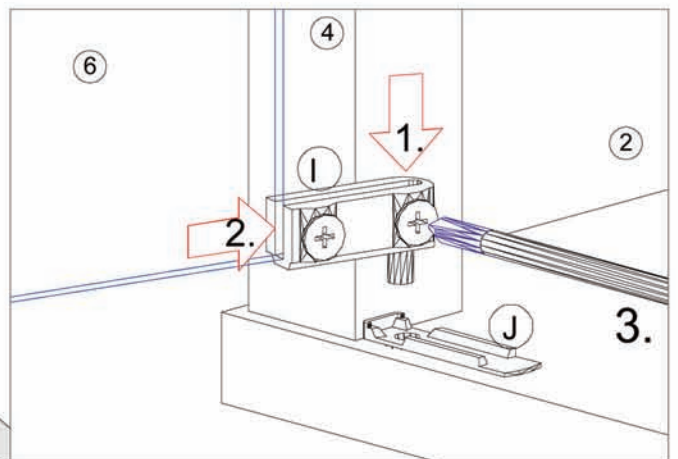
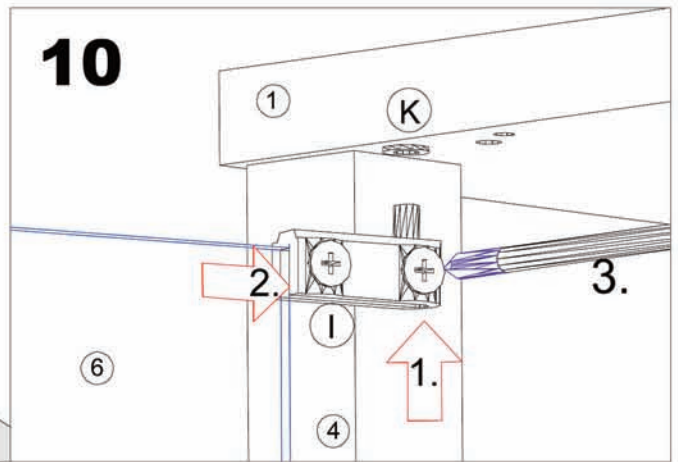
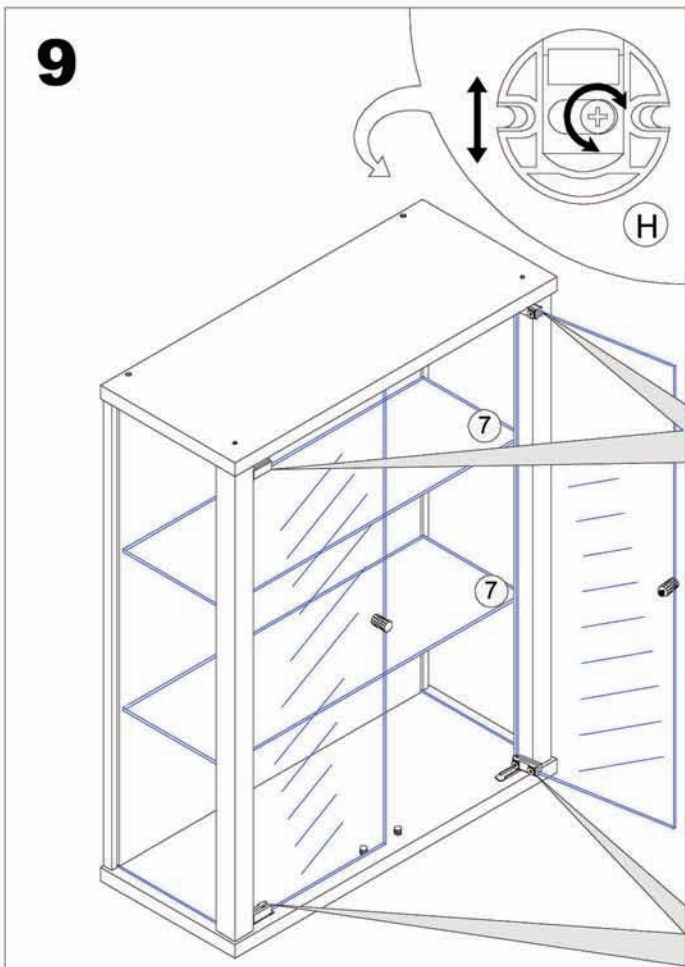
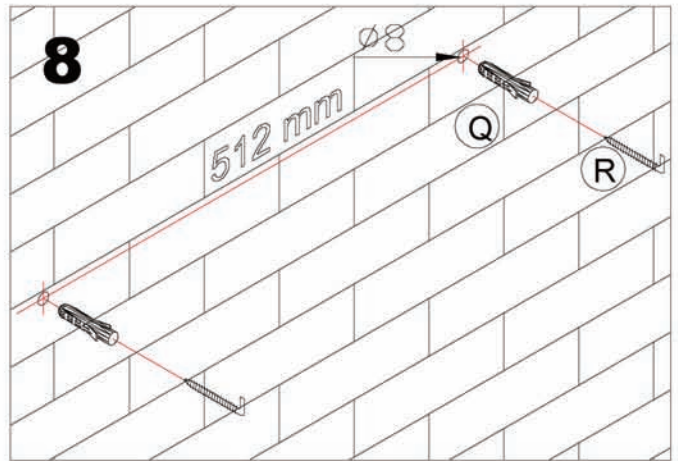
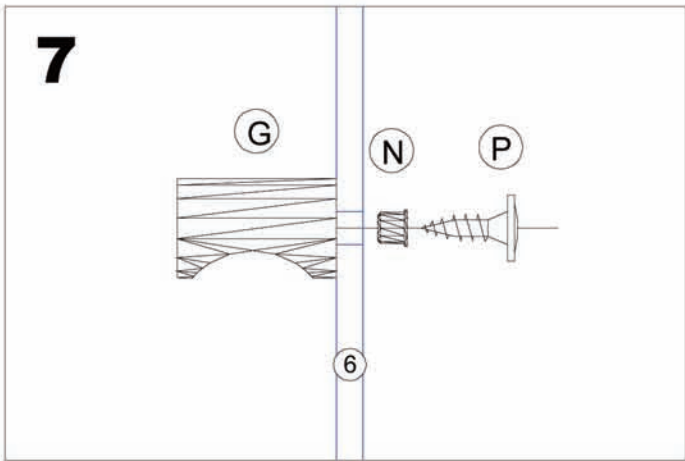
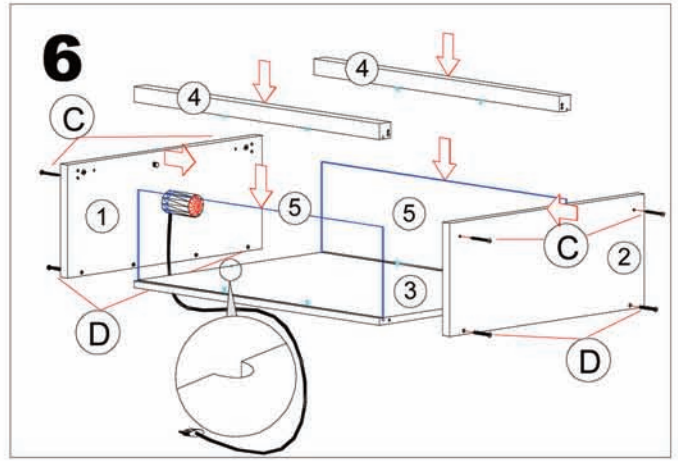
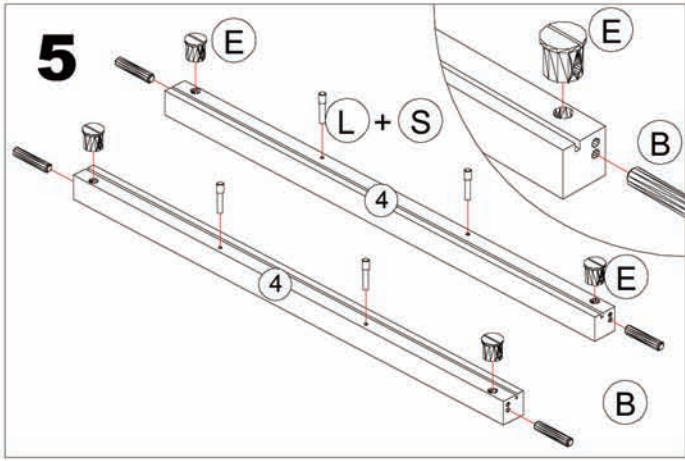

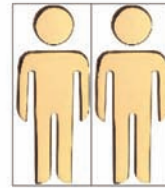
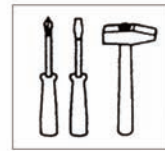
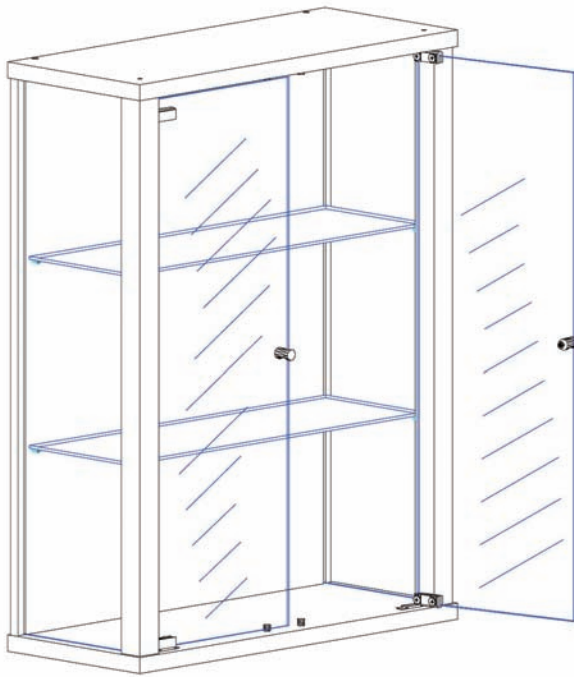

GB Assembly Instruction

Please assemble the glass cabinet according to numerical order of the drawings (1,2,3...) and put packs in horizontal position before opening. Open hardware bag carefully and sort contents in a box. In case of queries or complaints please advise full item number.
 Maintenance: Clean the glass cabinet with a humid cloth. Stain or dirt should be removed by using a soapy sponge. Avoid solvents or any chemical cleaner!
Caution! Maximum weight load for each glass shelf is 8 kg. Extreme care should be taken to avoid exceeding the total limit per shelf.

Customers who bought this item also bought...



Display cabinet single lock
Code: DCL1



Display Lifts & Risers
Code: LC



Counter Top Holders



Shelf barkers/ ticket strips
Code: PH075, PH032, LH25C, LH25B & LH25R



Display Cleaner / Micro fibre Cloth
Code: AG01 & AG04